

GSP2P404AL

2.3-2.4 GHz 4 W Power Amplifier

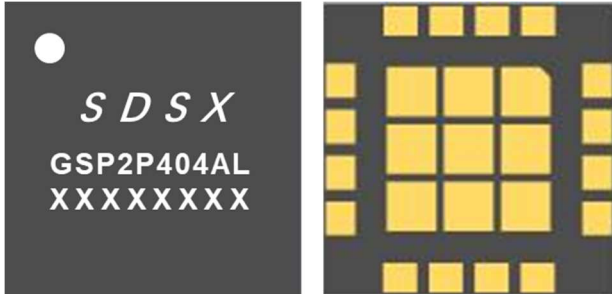

Description

The GSP2P404AL is a high-gain power amplifier (PA) with high power added efficiency (PAE) and linearity. The product is fully input and output matched to 50 Ω system. The compact 5x5 mm PA is designed for FDD and TDD 2G/3G/4G LTE small cell base stations operating from 2.3 to 2.4 GHz. The active biasing circuitry is integrated to compensate PA.

Features

- High efficiency: PAE = 35.5% @ +28 dBm
- High linearity: +28 dBm with < -50 dBc linearized ACPR (20 MHz LTE, 8.5 dB PAR signal)
- High gain: 36 dB @ +28 dBm
- Integrated active bias compensated over temp
- Integrated enable On/Off function: PAEN = 2 V
- On chip ESD protection
- Compact package: 16-pin, 5 x 5 x 0.85 mm

Functional Block Diagram

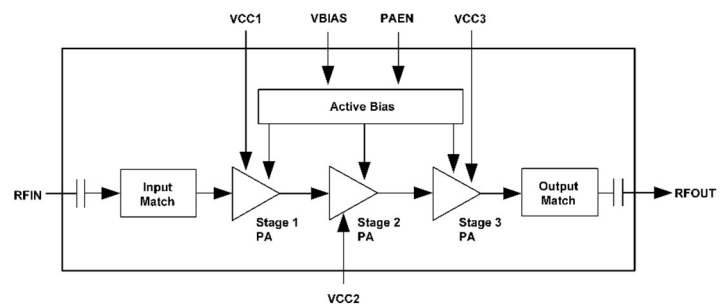

Applications

- FDD and TDD 2G/3G/4G LTE systems
- 3GPP band 30 and 40 small-cell base stations
- Driver amplifier for micro-base and macro-base stations
- Active antenna array and massive MIMO

Ordering Information

- GSP2P404AL

GSP2P404AL

2.3-2.4 GHz 4 W Power Amplifier



Recommended Operating Conditions

Parameter	Units	Min	Typ	Max
Supply voltage (VCC1, VCC2, VCC3, VBIAS)	V	4.75	5	5.25
PA enable (PAEN):				
ON	V	1.7	2.0	2.5
OFF	V	0	0	0.5
PA enable current	μ A	—	1	—
Operating frequency	MHz	2300	—	2400
Operating temperature	$^{\circ}$ C	-40	+25	+85
RF turn-on/turn-off time	μ s	—	1	—

Absolute Maximum Ratings

Parameter	Units	Min	Typ	Max
RF input power (CW, 50 Ω load, T=25 $^{\circ}$ C)	dBm	—	—	+10
Supply voltage (VCC1, VCC2, VCC3, VBIAS)	V	—	—	5.5
PA enable	V	—	—	3
Operating temperature	$^{\circ}$ C	-40	—	+100
Storage temperature	$^{\circ}$ C	-55	—	+125
Junction temperature	$^{\circ}$ C	—	—	+150
Power dissipation @ +28 dBm output power	W	—	—	TBD
Device thermal resistance @ +28 dBm output power	$^{\circ}$ C/W	—	—	TBD
ESD Rating	HBM	V	—	1000
	CDM	V	—	500

GSP2P404AL

2.3-2.4 GHz 4 W Power Amplifier



Electrical Specifications

Test Conditions: 50 Ω system, VCC1 = VCC2 = VCC3 = VBIAS = 5 V, PAEN = 2.0 V, f = 2350 MHz, TC = +25 °C.

Parameter	Conditions ⁽¹⁾	Units	Min	Typ	Max
Frequency	—	MHz	2300	—	2400
Small signal gain	PIN = -30 dBm	dB	—	35	—
Gain @ +28 dBm	POUT = +28 dBm	dB	—	36	—
Input return loss	PIN = -30 dBm	dB	—	-13	—
Output return loss	PIN = -30 dBm	dB	—	-7	—
OP1dB	100 μ s/1 ms, 10% duty cycle	dBm	—	34.5	—
Saturated Output power	100 μ s/1 ms, 10% duty cycle	dBm	—	36.4	—
Power Added efficiency	POUT = +28 dBm	%	—	35.5	—
ACPR(Uncorrected) ⁽²⁾	POUT = +28 dBm	dBc	—	-27	—
ACPR(Uncorrected) ⁽³⁾	POUT = +28 dBm	dBc	—	-25	—
ACPR(Corrected) ⁽²⁾	POUT = +28 dBm	dBc	—	-50	—
Quiescent current	No RF signal	mA	—	120	—
2nd harmonic	CW, POUT = +28 dBm	dBc	—	-30	—
3rd harmonic	CW, POUT = +28 dBm	dBc	—	-50	—

Notes:

1. Test conditions unless otherwise noted: All VCC & VBIAS = +5.0 V, PAEN = +2 V, Temp = +25 °C, 50 Ω system, f = 2350 MHz
2. LTE, 20 MHz E-UTRA Test Model 1.1 or 3.1, PAR = 8.5 dB
3. LTE, 20 MHz x 3 E-UTRA Test Model 1.1 or 3.1, PAR = 8.5 dB.

GSP2P404AL

2.3-2.4 GHz 4 W Power Amplifier



Pin Assignments and Description

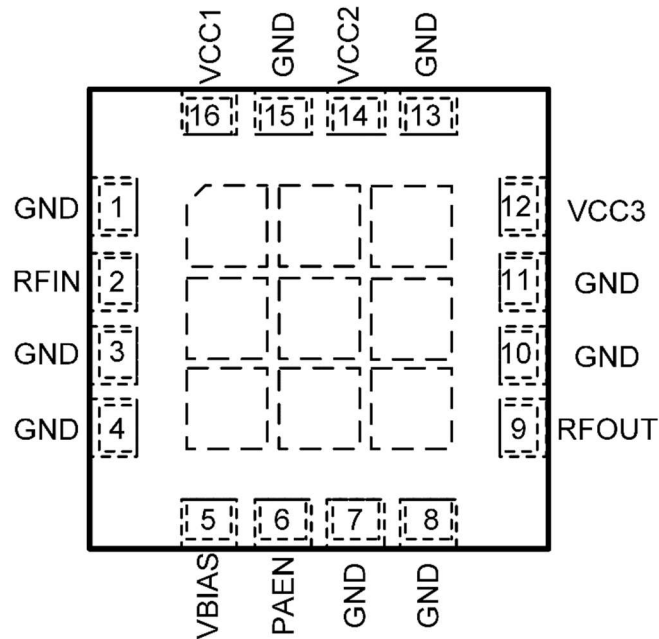

Pin	Name	Description
1	GND	Ground
2	RFIN	RF input port
3	GND	Ground
4	GND	Ground
5	VBIAS	Bias voltage
6	PAEN	PA enable
7	GND	Ground
8	GND	Ground
9	RFOUT	RF output port
10	GND	Ground
11	GND	Ground
12	VCC3	Stage 3 collector voltage
13	GND	Ground
14	VCC2	Stage 2 collector voltage
15	GND	Ground
16	VCC1	Stage 1 collector voltage

GSP2P404AL

2.3-2.4 GHz 4 W Power Amplifier



PCB Evaluation Board Schematic

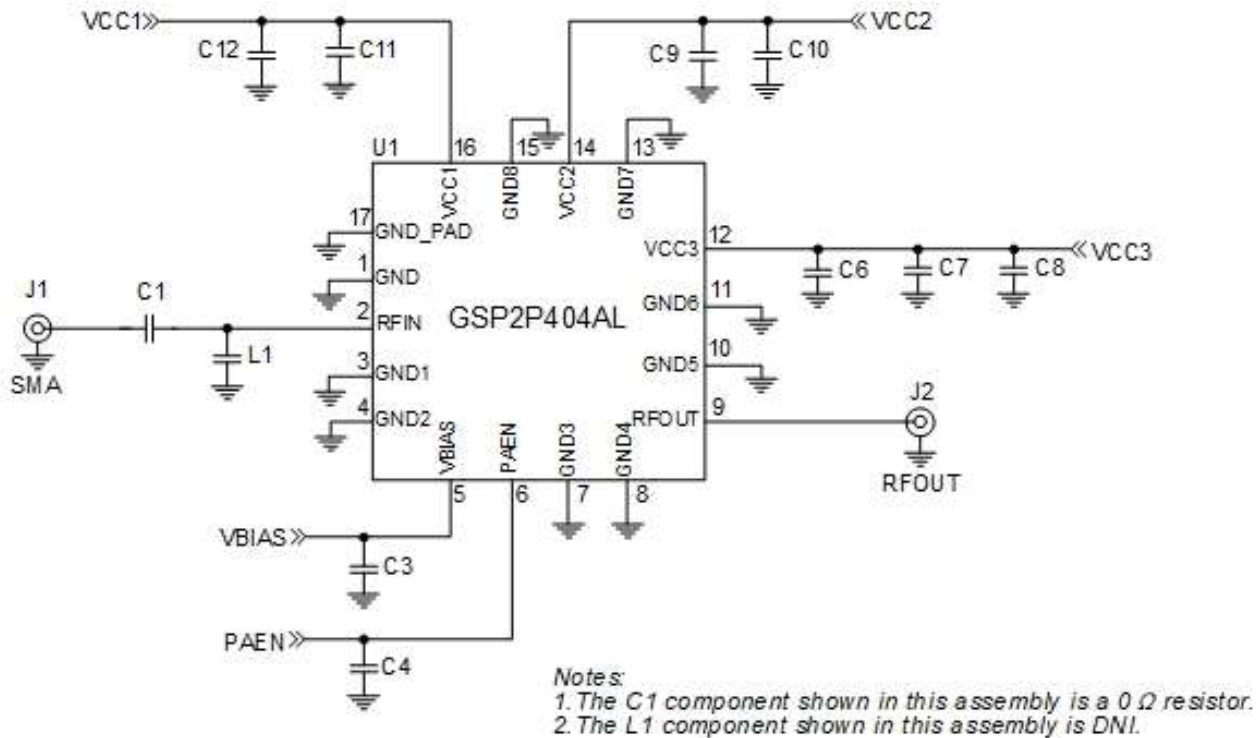

Evaluation Board BOM

Reference Des.	Value	Manuf.	Part Num.
PCB	N/A	SDSX	GSP2P404AL-EVB
Q1	N/A	SDSX	GSP2P404AL
C1 ⁽¹⁾	0 Ω	Murata	0402
C3, C6	1 μF	Murata	0402
C4, C7	3300 pF	Murata	0402
C9	470 nF	Murata	0402
C11	100 nF	Murata	0402
C8, C10, C12	10 μF	Murata	1206
L1		DNI	

Notes:

1. The C1 component shown in this assembly is a 0 Ω resistor.

GSP2P404AL

2.3-2.4 GHz 4 W Power Amplifier



Typical Performance Characteristic

Test Conditions: VCC1 = VCC2 = VCC3 = VBIAS = 5 V, PAEN = 2 V, f = 2350 MHz, T = +25 °C,
Input/Output Load = 50 Ω, Unless Otherwise Noted.

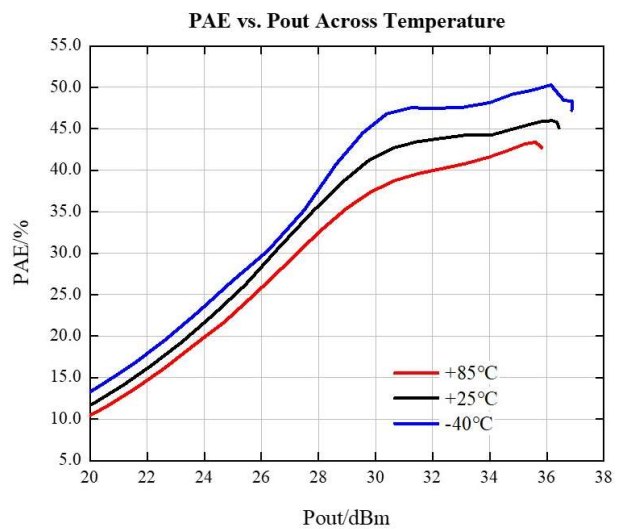
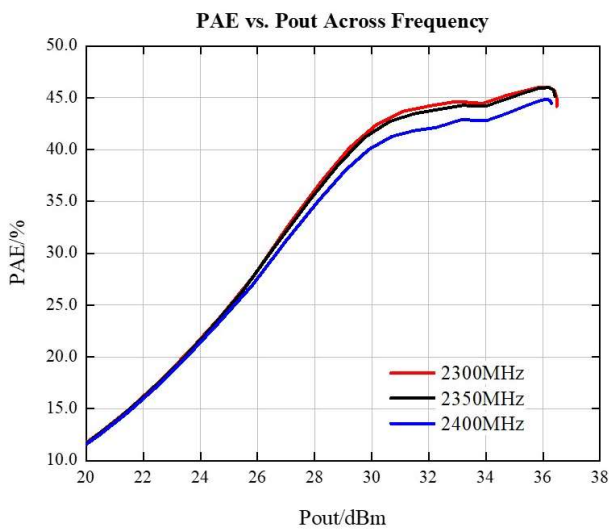
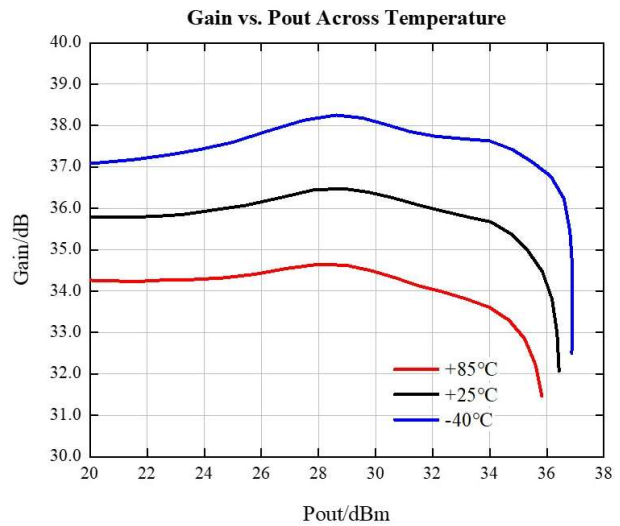
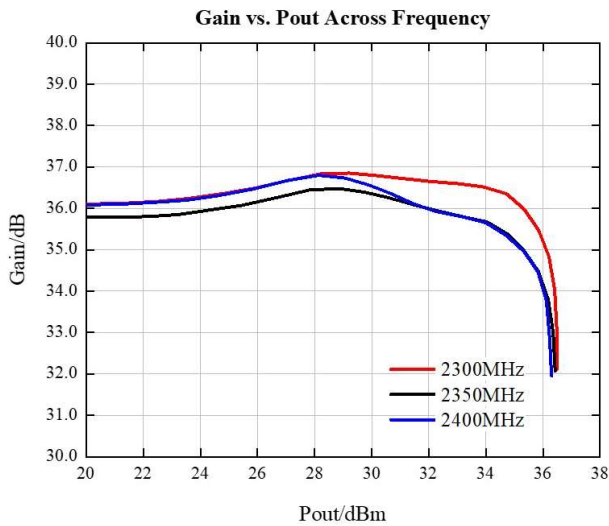

GSP2P404AL

2.3-2.4 GHz 4 W Power Amplifier



Typical Performance Characteristic

Test Conditions: VCC1 = VCC2 = VCC3 = VBIAS = 5 V, PAEN = 2 V, f = 2350 MHz, T = +25 °C,
Input/Output Load = 50 Ω, Unless Otherwise Noted.

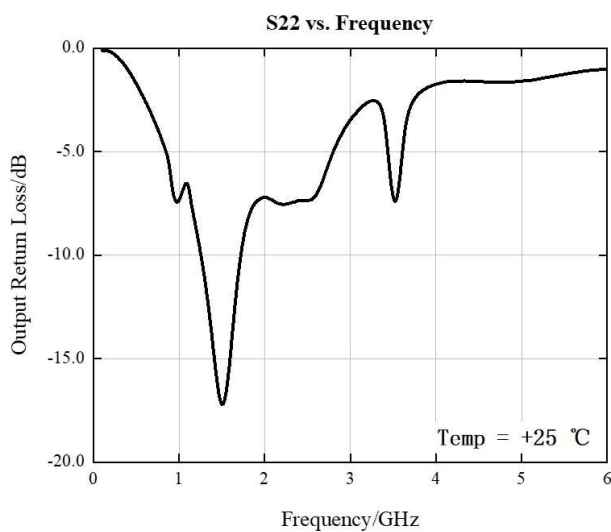
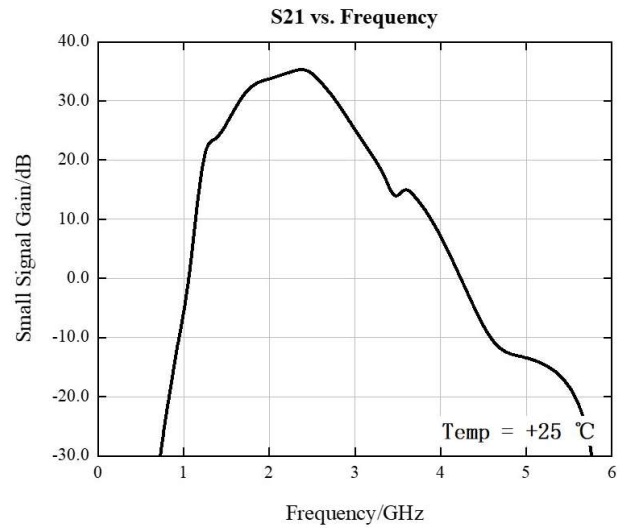
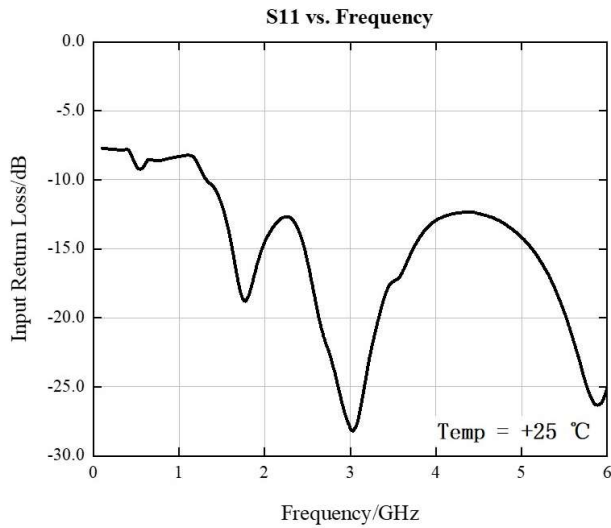

GSP2P404AL

2.3-2.4 GHz 4 W Power Amplifier



Handling Precaution

ESD countermeasure methods should be developed and used to control potential ESD damage during handling in a factory environment at each manufacturing site.

Solderability

Compatible with lead-free (260 °C maximum reflow temperature) soldering processes.

RoHS Compliance

This product is compliant with the EU RoHs2.0, EU Directive 2015/863.

Contact Information

Tel: 86-(0)755-82522200

Email: sales@sdsxchip.com

Address: #318, Floor 3, Block A, SDCIC Mansion, 6 Guanglan Rd,
Futian Free Trade Zone, Futian Dist., Shenzhen

Website: www.sdsxchip.com